

MATRIX

T1x
T3x

T1xe
T3xe

T3xh





MATRIX

AUSTRALIA

Johnson Health Tech Australia
6B Hazelwood Drive
Morwell
VIC 3840 AUSTRALIA
Tel: +61 1300 760 601
www.matrixfitness.com

BRAZIL

Johnson Health Tech Brasil
Estrada Municipal, 200 – mód 14 e 15 – gleba 3
Chácara Alvorada
Indaiatuba, SP
CEP 13337-200 BRASIL
Tel: +55-19-2107-5300
br.matrixfitness.com

CANADA

Johnson Health Tech Canada
10401, Ray-Lawson Blvd.
Montreal, Quebec H1J 1M3
CANADA
Tel: 514-336-0006
www.matrixfitness.com

CHINA

Johnson Health Tech (Shanghai) Co., Ltd.
Rm 508-512
HuaWen Plaza 999 Zhongshan
(West) Road
Changning District
Shanghai, 200050 CHINA
Tel: +86-021-32503800
www.johnsonfitness.com.cn

FRANCE

Johnson Health Tech France
45, avenue Georges Politzer
Trappes
78190 FRANCE
Tel: +33 01 30 68 62 80
www.matrixfitness.fr

GERMANY / AUSTRIA

Johnson Health Tech. GmbH
Nikolaus-Otto-Str. 1
D-22946 Trittau GERMANY
Tel. +49 (0)4154-7952-0
www.matrixfitness.eu

GREECE

Johnson Health Tech Hellas SA
12 Vas. Konstantinou Avenue
116 35 Athens GREECE
Tel: +20 211 4112797
www.Johnson Health Tech.gr

HONG KONG

Johnson Health Tech (HK) Limited
Room 1501-1502, Aitken Vanson Centre,
61 Hoi Yuen Road, Kwun Tong
Kowloon
HONG KONG
Tel: +852-2302 0596
hk.matrixfitness.com

IBERIAN PENINSULA (SPAIN, PORTUGAL)

Johnson Health Tech Ibérica
Avenida de la Astronomía, 4 nave 9.2
San Fernando de Henares
28830 Madrid - ESPAÑA
Tel: +34-91 6293 688
www.matrixfitness.es

ITALY

Johnson Health Tech Italia Spa
Zona Ind.le Campolungo 11
63100 Ascoli Piceno (AP)
ITALY
Tel: +39 0736 22699
www.matrixfitness.it

JAPAN

Johnson Health Tech Japan
Yasuda Bldg. 2F,
3-3-8 Kaigan,
Minato-ku Tokyo 108-8435
JAPAN
Tel: +81-3-5419-3560
www.matrixfitness.jp

KOREA

Johnson Health Tech Co., Ltd. Korea Branch
203 ho, A-Block Richensia Young
San133-3 Wonhyoro 1-ga, Young San
Gu, 140-111 Seoul
SOUTH KOREA
Tel: +82-2-6731-0175
kr.matrixfitness.com

MALAYSIA

Johnson Fitness (Malaysia) Sdn. Bhd.
Lot 557D, Jalan Subang 3
Subang Jaya Industrial Estate
47610 Subang Jaya
Selangor MALAYSIA
Tel: +60-603-5632 8273
my.matrixfitness.com

NETHERLANDS (BELGIUM, DENMARK, LUXEMBOURG)

Matrix Fitness / Johnson Health Tech. Netherlands
Vleugelboot 14
3991 CL Houten
NETHERLANDS
Tel: +31 30 24 45 435
www.matrixfitness.nl

PHILIPPINES

Johnson Health Tech. Commercial Philippines Inc.
15th Floor, Citibank Center, 8741 Paseo de Roxas,
Makati City, Metro Manila, 1226 PHILIPPINES
Tel: +63-2-558-6590
world.matrixfitness.com

POLAND

Johnson Health Tech Poland
ul. Działkowa 62
02-234 Warszawa POLAND
Tel: +49 2234 9997-100
pl.matrixfitness.com

SWITZERLAND

Johnson Health Tech. (Schweiz) GmbH
Althardstrasse 185
CH-8105 Regensdorf SWITZERLAND
Tel. +41 (0)44-843 30 30
www.matrixfitness.ch

TAIWAN

Johnson Health Tech Taiwan
999, Sec 2, Dongda Rd., Daya Dist.,
Taichung City 428
TAIWAN (R.O.C)
Tel: +886-4-25667100
world.matrixfitness.com/zh

THAILAND

Johnson Health Tech Thailand
9th Floor, Unit 9B, Bangna Towers,
Tower A 2/3
Moo 14, Bangna-Trad Rd.
K.M. 6.5 Bangkaew, Pongplee
Samutprakan, 10540 THAILAND
Tel: +66-2751-9360
th.matrixfitness.com

UNITED ARAB EMIRATES

Johnson Health Tech. UAE
ICON Tower, Office #602
TECOM, Al Barsha
Dubai, United Arab Emirates
Tel: +971 4 4567939
world.matrixfitness.com/

UNITED KINGDOM

(ENGLAND, SCOTLAND, N. IRELAND, WALES)
Johnson Health Tech UK
Riverside park
Campbell Road
Stoke on Trent
ST4 4EY ENGLAND
Tel: +44-1782644900
www.matrixfitness.co.uk

UNITED STATES

Matrix Fitness / Johnson Health Tech NA
1600 Landmark Drive
Cottage Grove, WI 53527 USA
Toll Free: +1-866-693-4863
www.matrixfitness.com

VIETNAM

Johnson Health Tech (Vietnam) Co. Ltd.
Unit 2302, Lim Tower
9-11 Ton Duc Thang Street
Ben Nghe Ward, District 1
Ho Chi Minh City
VIETNAM
Tel: +84 909 977957
vn.matrixfitness.com

INTERNATIONAL (OTHER COUNTRIES)

Matrix Fitness International
999, Sec 2, Dongda Rd., Daya Dist.,
Taichung City 428
TAIWAN (R.O.C)
Tel: +886-4-25667100
world.matrixfitness.com



CONSOLE GUIDE

SERIAL NUMBER LOCATIONS

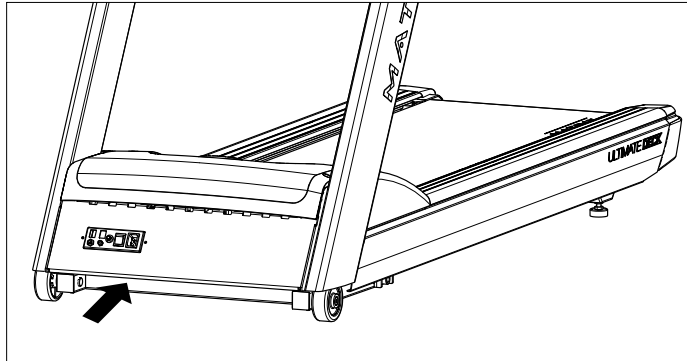
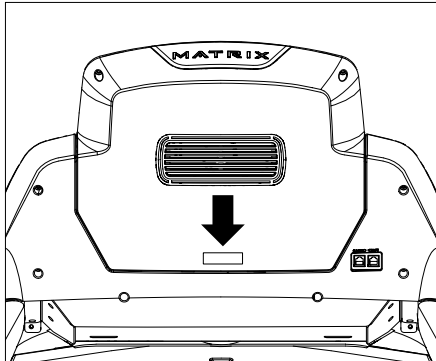

Before proceeding, find the serial numbers located on barcode stickers and enter them in the spaces provided below.

CONSOLE SERIAL NUMBER

FRAME SERIAL NUMBER

MODEL

 T1x T3x T1xe T3xe T3xh **MATRIX TREADMILL**

* Use the information above when calling for service.



T1X



T1X CONSOLE DESCRIPTION

The Matrix machine is inspected before it is packaged. It is shipped in two pieces: the base and the console. Carefully unpack the unit and dispose of the box material. Note: There is a thin protective sheet of clear plastic on the overlay of the console that should be removed before use.

- A) WORKOUT KEYS:** Simple program view and selection buttons. Press Fitness Test button to cycle through available tests.
- B) GO:** One Touch Start.
- C) ENTER:** To confirm each program setting.
- D) BACK:** Go to previous program setting.
- E) NUMBER KEYPAD:** Allows for easy number inputs.
- F) UP/DOWN INCLINE:** Adjust incline and make program selections.
- G) UP/DOWN SPEED:** Adjust speed and make program selections.
- H) UP/DOWN TIME:** Adjust workout time.
- I) TOGGLE DISPLAY:** Cycles between 3 rows of workout information displayed in LED window. The console will automatically cycle between the workout information if the Toggle Display button is pushed and held down for 3 seconds.
- J) EMERGENCY STOP / IMMOBILIZATION:** To stop all functions and immobilize the unit. The emergency stop on this treadmill must be returned to its original position in order to allow normal operation of the unit.
- K) STOP:** Ends workout and shows workout summary data.
- L) PAUSE:** Pauses workout. Pause duration can be set in manager or engineering mode.
- M) COOL DOWN:** Puts treadmill into Cool Down mode. Cool Down time is dependent on the length of the workout.



T3X

T3X CONSOLE DESCRIPTION

The Matrix machine is inspected before it is packaged. It is shipped in two pieces: the base and the console. Carefully unpack the unit and dispose of the box material. Note: There is a thin protective sheet of clear plastic on the overlay of the console that should be removed before use.

- A) **WORKOUT KEYS:** Simple program view and selection buttons. Press Fitness Test button to cycle through available tests.
- B) **GO:** One Touch Start.
- C) **ENTER:** To confirm each program setting.
- D) **BACK:** Go to previous program setting.
- E) **NUMBER KEYPAD:** Allows for easy number inputs.
- F) **UP/DOWN INCLINE:** Adjust incline and make program selections.
- G) **UP/DOWN SPEED:** Adjust speed and make program selections.
- H) **UP/DOWN TIME:** Adjust workout time.
- I) **TOGGLE DISPLAY:** Cycles between 3 rows of workout information displayed in LED window. The console will automatically cycle between the workout information if the Toggle Display button is pushed and held down for 3 seconds.
- J) **EMERGENCY STOP / IMMOBILIZATION:** To stop all functions and immobilize the unit. The emergency stop on this treadmill must be returned to its original position in order to allow normal operation of the unit.
- K) **STOP:** Ends workout and shows workout summary data.
- L) **PAUSE:** Pauses workout. Pause duration can be set in manager or engineering mode.
- M) **COOL DOWN:** Puts treadmill into Cool Down mode. Cool Down time is dependent on the length of the workout.

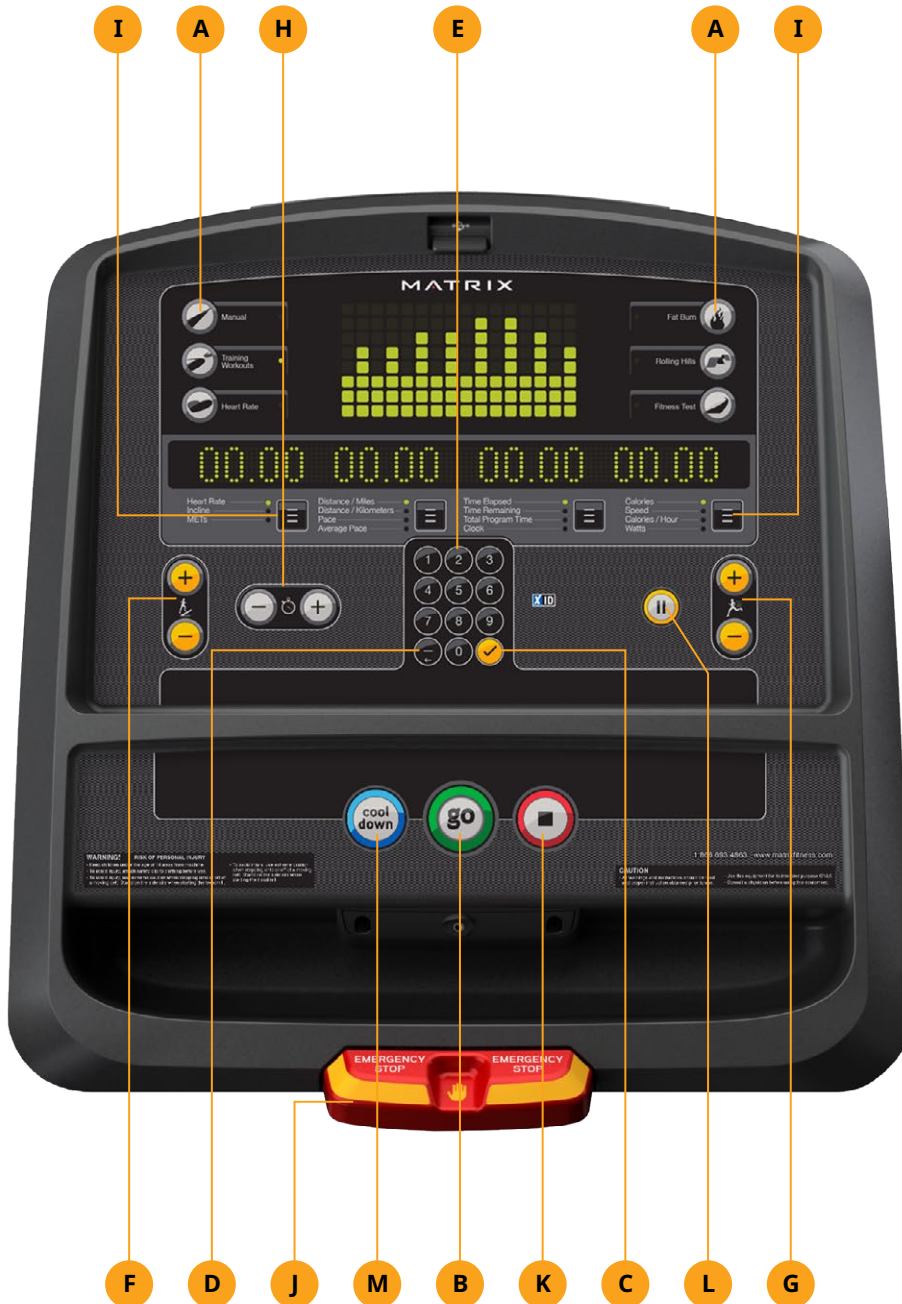



T1XE
T3XE



T1XE/T3XE CONSOLE DESCRIPTION

The Matrix machine is inspected before it is packaged. It is shipped in two pieces: the base and the console. Carefully unpack the unit and dispose of the box material. Note: There is a thin protective sheet of clear plastic on the overlay of the console that should be removed before use.

The T1xe/T3xe has a fully integrated touch screen display. All information required for workouts is explained on-screen. Exploration of the interface is highly encouraged. The information explaining how to program for various workouts will give an explanation about the contents of each screen on the T1xe/T3xe.

- A) GO:** One Touch Start.
- B) UP/DOWN INCLINE:** Adjust incline and make program selections.
- C) UP/DOWN SPEED:** Adjust speed and make program selections.
- D) PAUSE** (displayed on-screen during workout): Pauses workout. Pause duration can be set in manager or engineering mode. During pause, user can choose to stop or continue workout.
- E) COOL DOWN** (displayed on-screen during workout): Puts treadmill into Cool Down mode. Cool Down time is dependent on the length of the workout.
- F) EMERGENCY STOP / IMMOBILIZATION:** To stop all functions and immobilize the unit. The emergency stop on this treadmill must be returned to its original position in order to allow normal operation of the unit.
- G) VOLUME UP/DOWN:** Adjusts the volume output through headphones.
- H) CHANNEL UP/DOWN:** Allows for channel selection on the integrated console TV.
- I) HOME:** Will take the user back to the home screen.
- J) LAST CHANNEL:** Allows the user to cycle between the current channel and the previous channel they were viewing.
- K) DISPLAY MODE:** Allows user to cycle through display modes.
- L) CC/MUTE:** Mutes sound and turns closed captioning on or off.
- M) NUMBER KEYPAD:** Allows for easy number inputs.



T3XH

T3XH CONSOLE DESCRIPTION (SIMPLE MODE)

The Matrix machine is inspected before it is packaged. It is shipped in two pieces: the base and the console. Carefully unpack the unit and dispose of the box material. Note: There is a thin protective sheet of clear plastic on the overlay of the console that should be removed before use.

The T3xh has a fully integrated touch screen display. All information required for workouts is explained on-screen. Exploration of the interface is highly encouraged. The information explaining how to program for various workouts will give an explanation about the contents of each screen on the T3xh.

- A) **GO/STOP:** One touch start (displayed on-screen before workout). Press to end workout and show workout summary data.
- B) **UP/DOWN INCLINE:** Adjust incline during workout.
- C) **UP/DOWN SPEED:** Adjust speed during workout.
- D) **PAUSE:** Pauses workout. Pause duration can be set in manager or engineering mode.
- E) **EMERGENCY STOP / IMMOBILIZATION:** To stop all functions and immobilize the unit. The emergency stop on this treadmill must be returned to its original position in order to allow normal operation of the unit.
- F) **NOTE:** Entertainment features are not enabled in simple mode.









T1XE
T3XE

T1XE/T3XE CONSOLE OPERATION

GETTING STARTED

- Touch the **USER** button to sign-in with your XID.
- Touch the **GUEST** button to workout anonymously.
- Touch the **REGISTER** button to create a new XID.
- For help or more information, touch .
- To change language, touch .

USER SIGN-IN

- 1) Enter your **XID** and touch .
- 2) Enter your **PASSCODE** and touch .

REGISTER A NEW USER

- 1) Don't have an xID account? Registration is easy.
- 2) Follow the on-screen prompts to create your free account.
- 3) Review your information and select the **I ACCEPT THE TERMS AND CONDITIONS** box to review the Terms and Conditions.
- 4) Touch  to complete registration. Your account is now active and you are signed-in.

LOGIN SCREEN

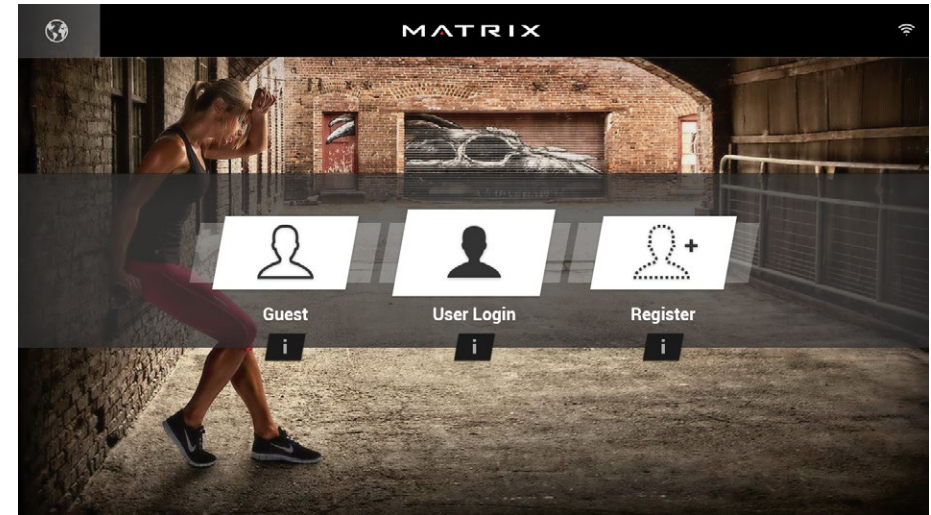

GO SCREEN

- Touch **GO** to begin working out immediately. Or...
- Touch the **WORKOUT CATEGORY** button of your choice to customize your workout.

PROGRAM SETUP

- 1) After selecting a **WORKOUT CATEGORY** button, select one of the **PROGRAMS** listed to the left.
For more information on a selected program, touch .
- 2) Use the **SLIDER CONTROLS** to adjust your program settings.
- 3) Press **GO** to begin your workout.

Note: Workouts and features vary based on model type, console configurations, software versions and options purchased.

GO SCREEN

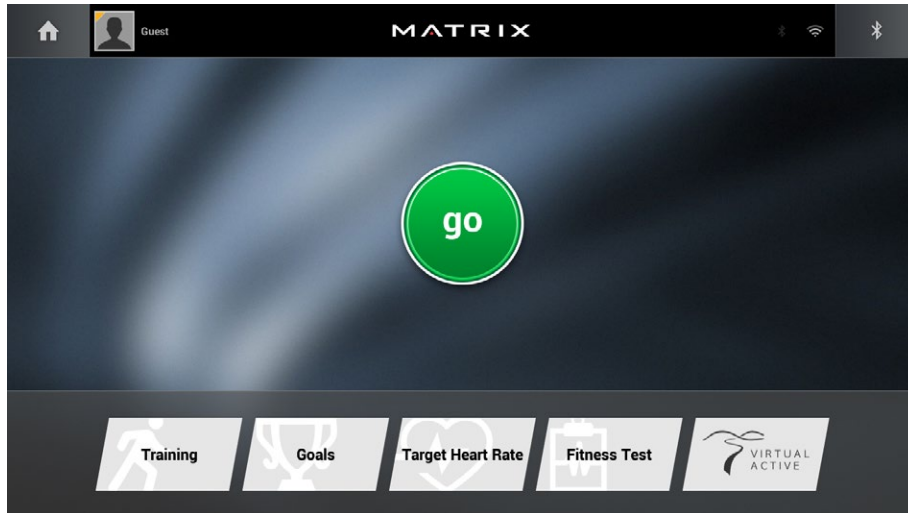

PROGRAM SETUP

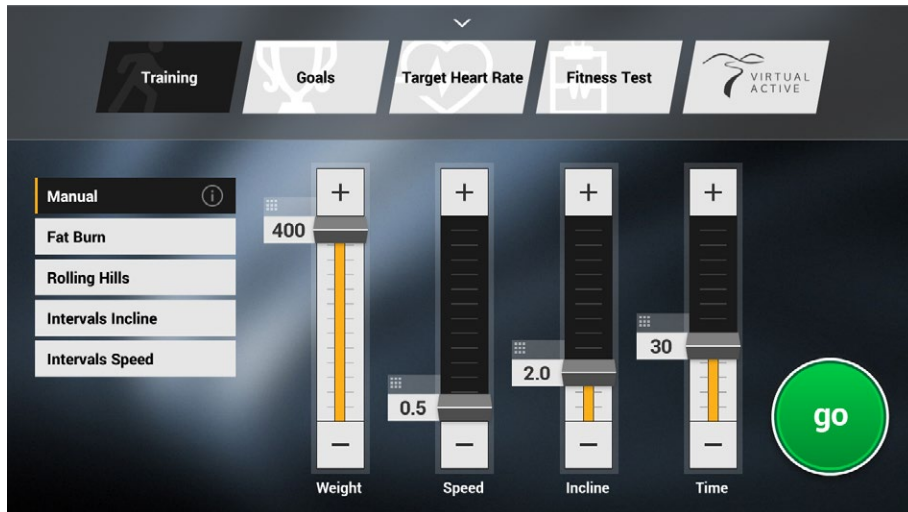

Note: Workouts and features vary based on model type, console configurations, software versions and options purchased.

HOME SCREEN



HOME SCREEN

- The **USERNAME** or **GUEST** is shown in the upper left corner.
- Touch **≡** to change **WORKOUT STATISTICS** displayed at the bottom of the screen.
- Touch **🏠** to go back to the home screen whenever you're using an app.
- Touch **⚙️** to adjust **VOLUME**, pair a **BLUETOOTH** device or to change **AUDIO SOURCE** (TV, My Media, Virtual Active, etc.).
- Touch **↓↑** to increase or decrease the intensity level, speed or incline.
- Touch **⌨️** to use the keypad to set intensity level, speed or incline. Press **⏹️** to confirm change.
- Touch **↶** to change intensity level, speed or incline back to previous setting.
- Touch **⏸️** to temporarily pause your workout and touch **▶️** to resume. **NOTE:** After resuming, speed, incline and intensity levels will be reset.
- While paused, touch **■** to end workout.
- Touch **−+** to increase or decrease the duration of your workout.
- Touch **📉** to enter cool down mode. Cool down lasts for a few minutes while reducing the workout intensity, allowing your body to recover from your workout.
- Touch **🔒** to lock the screen in order to prevent accidental screen touches from being implemented. Touch it again to unlock the screen and allow screen touches.



T1XE
T3XE



T1XE
T3XE

APPS AND ENTERTAINMENT



SIMPLE

Workout stats are displayed in 3 customizable windows.



TRACK

Displays a 400 M (1/4 MILE) track. Split feature allows you to keep track of your fastest laps and improve your time.



VIRTUAL ACTIVE

Your workout info is displayed and Virtual Active courses are shown. With Virtual Active, escape the confines of an ordinary workout as you or walk or run through exotic destinations.



TARGET HEART RATE

Track your progress while working out to a Target Heart Rate program.



FITNESS TEST

Track your progress while working out to a Fitness Test program.



CHANGE WORKOUT

Select a different workout without stopping your current workout.



MY MEDIA

Connect and control audio and video files on-screen via USB port or Bluetooth.



TV

Watch live TV.



WEATHER

Get local weather info.



WEB BROWSER

Access the world wide web while you work out.



FACILITY CALENDAR

View Facility event schedule and other info.



YOUTUBE

Browse and watch YouTube videos while you work out.



FACEBOOK

Browse your Facebook page while you work out.



TWITTER

Access your Twitter feed while you work out.



NETFLIX

Browse and watch Netflix videos while you work out. Netflix account required to access content.



HULU PLUS

Browse and watch Hulu Plus videos while you work out. Hulu Plus account required to access content.



VEVO

Browse and watch Vevo videos while you work out. Vevo account required to access content.



VUDU

Browse and watch Vudu videos while you work out. Vudu account required to access content.



MYFITNESS PAL

Lose weight with MyFitnessPal, the fastest and easiest to use calorie counter.

Note: Workouts and features vary based on model type, console configurations, software versions and options purchased.

**NOTE:**

This equipment has been tested and found to comply with the limits for a Class B digital device, pursuant to part 15 of the FCC rules. These limits are designed to provide reasonable protection against harmful interference in a residential installation. This equipment generates, uses and can radiate radio frequency energy and, if not installed and used in accordance with the instructions, may cause harmful interference to radio communications. However, there is no guarantee that interference will not occur in a particular installation. If this equipment does cause harmful interference to radio or television reception, which can be determined by turning the equipment off and on, the user is encouraged to try to correct the interference by one or more of the following measures:

- Reorient or relocate the receiving antenna.
- Increase the separation between the equipment and receiver.
- Connect the equipment into an outlet on a circuit different from that to which the receiver is connected.
- Consult the dealer or an experienced radio/TV technician for help.

Any changes or modifications not expressly approved by the party responsible for compliance could void the user's authority to operate this equipment.

FCC RF Radiation Exposure Statement:

1. This Transmitter must not be co-located or operating in conjunction with any other antenna or transmitter.
2. This equipment complies with FCC RF radiation exposure limits set forth for an uncontrolled environment. This equipment should be installed and operated with a minimum distance of 20 centimeters between the radiator and your body

MATRIX