

**BODYWORX**

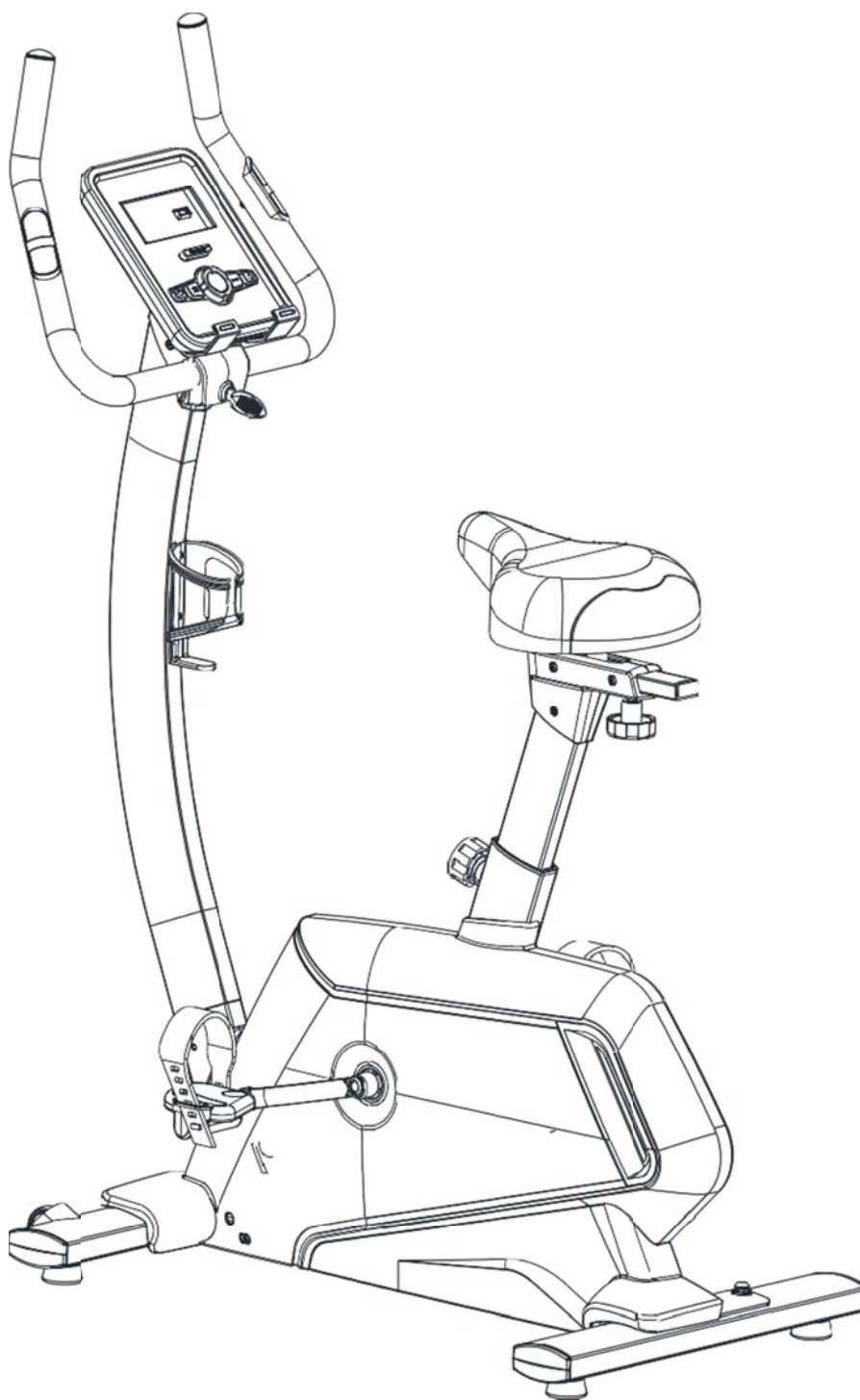

# UPRIGHT BIKE

**Model No: ABX600**



**Retain this owner's manual for future reference.  
Read and follow all instructions in this owner's manual.**

**Version A**



# Warranty Registration Form

Congratulations on purchasing your product, we at GPI believe that our product range is of the highest quality and represents great value for money.

We back our product range up with our industry leading warranty.

Please see below for the step by step instructions on how to register your product warranty online.



---

## Step 1 Visit our Website

Go to the GPI Sports website: [www.gpisports.com.au/warranty](http://www.gpisports.com.au/warranty)



---

## Step 2 Enter Purchase Information

Enter all purchase information including the serial number and proof of purchase which can be uploaded from this page



---

## Step 3 Call Our Toll Free Number

If a warranty service request is required on your product please call the toll free number - **1800 005 770**

# *Safety Instructions*

- To ensure the best safety of the exerciser, regularly check for damage and worn parts.
- If you pass on this exerciser to another person or if you allow another person to use it, make sure that that person is familiar with the content and instructions.
- Only one person should use the exerciser at a time.
- Before the first use and regularly make sure that all screws, bolts and other joints are properly tightened and firmly fixed.
- Before you start your work-out, remove all sharp-edged objects around the exerciser.
- Only use the exerciser for your work-out if it works without problem.
- Any broken, worn or defective part must immediately be replaced and/or the exerciser must no longer be used until it has been properly maintained and repaired.
- Children should use the exerciser only under adult supervision and be instructed on the correct and proper use of the exerciser. The exerciser is not a toy.
- Make sure there is sufficient free space around the exerciser when you set it up.
- Please note that an improper and excessive work-out may be harmful to your health.
- Please note that levers and other adjustment mechanisms are not projecting into the area of movement during the work-out.
- Always wear appropriate clothing and shoes which are suitable for your work-out on the exerciser. The clothes must be designed in a way so that they will not get caught in any part of the exerciser during the work-out due to their form (for example, length). Be sure to wear appropriate shoes which are suitable for the work-out, firmly support the feet and which are provided with a non-slip sole.
- Be sure to consult a physician before you start any exercise program.
- Be sure to set up the exerciser in a dry and even place and always protect it from humidity. If you wish to protect the place particularly against pressure points, contamination, etc., it is recommended to put a suitable, non-slip mat under the exercise.
- Stop your work-out immediately in case of dizziness, nausea, chest pain or any other physical symptoms. In case of doubt, consult your physician immediately.
- Children, disabled and handicapped persons should use the exercise only under supervision and in presence of another person who may give support and useful instructions.
- Be sure that your body parts and those of other persons are never close to any moving parts of the exerciser during its use.
- When adjusting the adjustable parts, make sure they are adjusted properly and note the marked, maximum adjusting position, for example of the saddle support, respectively.
- Do not work out immediately after meals!

# Warming up:



15 seconds for each



20 seconds

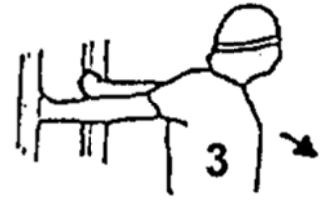

20 seconds



25 seconds



20 seconds



20 seconds



30 seconds



25 seconds for each leg



30 seconds



20 seconds



5 seconds x 3 times



20 seconds



20 seconds for each leg



5 times



15 seconds

# Hardware Kits

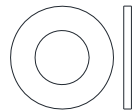

28  $\Phi$ 10-4



27  $\Phi$ 10-4



29 M4 $\times$ 6-6

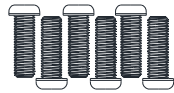

32 M4 $\times$ 16-6

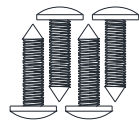

87 ST4 $\times$ 12-4

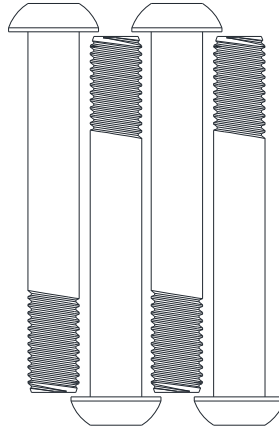

26 M10 $\times$ 70 $\times$ 20-4



31 M12 $\times$ 60-2

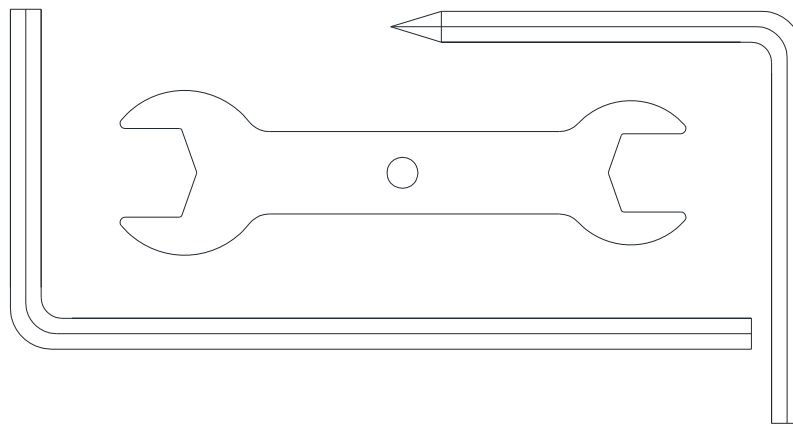

NO.	NAME	SPECIFICATION	QUANTITTY
26	Allen C.K.S. half thread screw	M10 $\times$ 70 $\times$ 20	4
27	Flat washer	$\Phi$ 10	4
28	Spring washer	$\Phi$ 10	4
29	Philips pan head full thread screw	M4 $\times$ 6	6
31	Allen flat end set bolt	M12 $\times$ 60(12.9 level)	2
32	Philips pan head full thread screw	M4 $\times$ 16	6
87	Phillips C.K.S. self-tapping screw	ST4 $\times$ 12	4
	L-shaped wrench	5 $\times$ 80 $\times$ 80S	1
	L-shaped wrench	6 $\times$ 66 $\times$ 140	1
	Open-end wrench	t4.0 $\times$ 38 $\times$ 145	1

# Assembly Instruction

## **STEP1.**

#26	#27	#28	<b>X2</b>
			

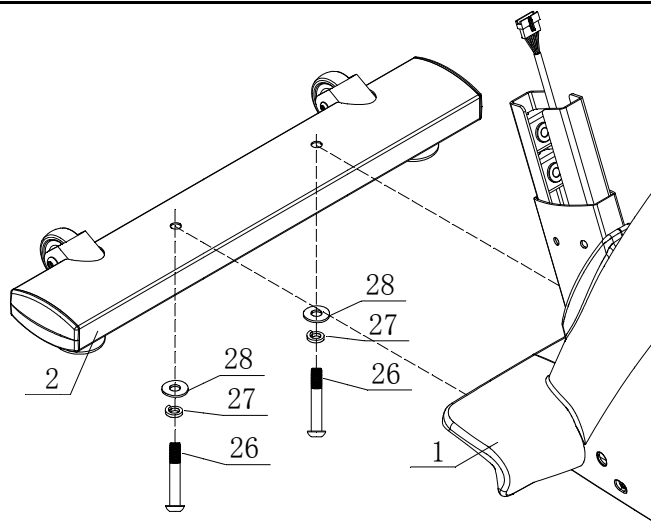

## **STEP2.**

#26	#27	#28	<b>X2</b>
			

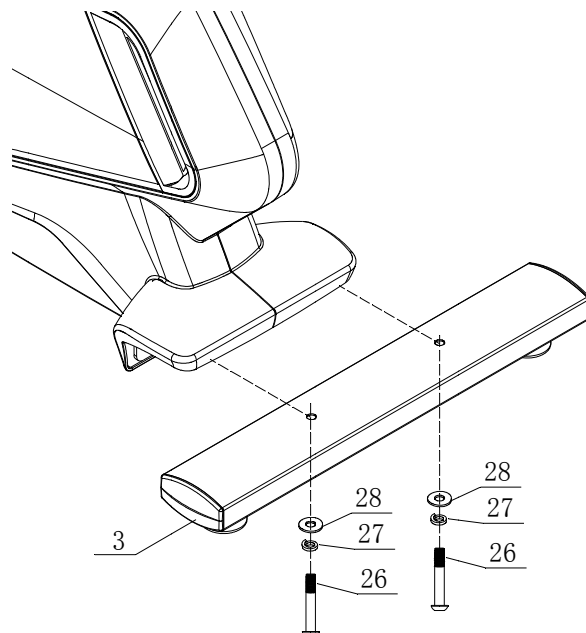

## **STEP3.**

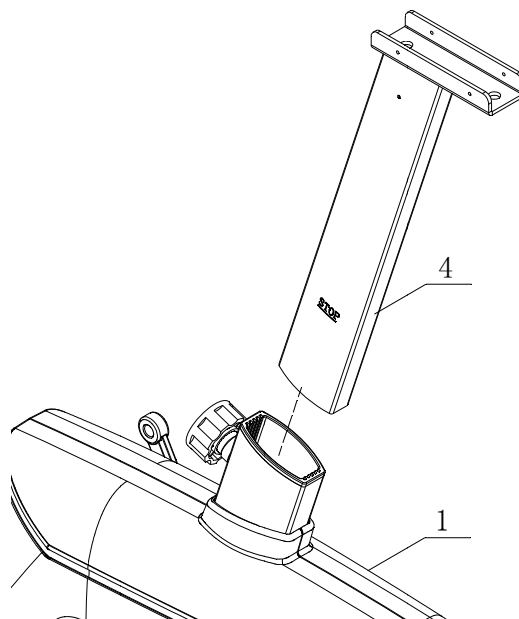

# Assembly Instruction

## STEP 4.

#59	<b>X3</b>
	

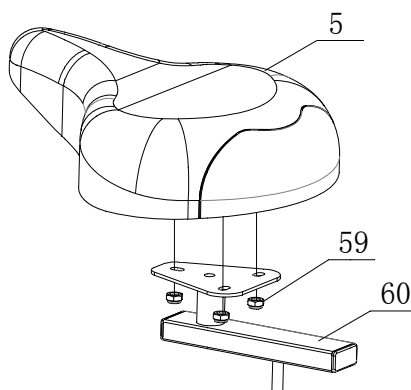

## STEP 5.

#29	<b>X6</b>
	

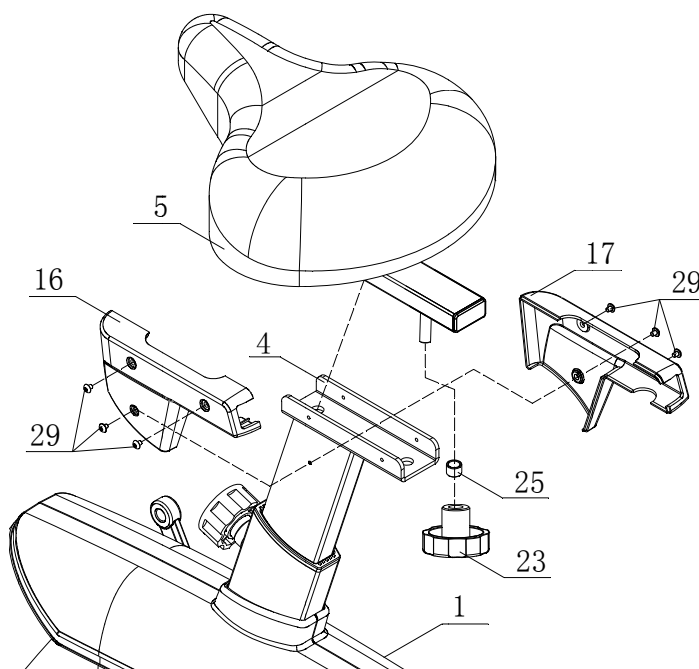

## STEP 6.

#31	<b>X2</b>
	

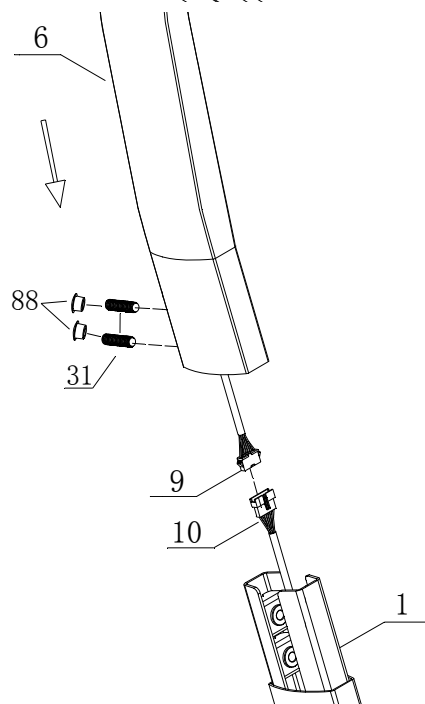

# Assembly Instruction

## STEP 7.

#32	<b>X2</b>
	

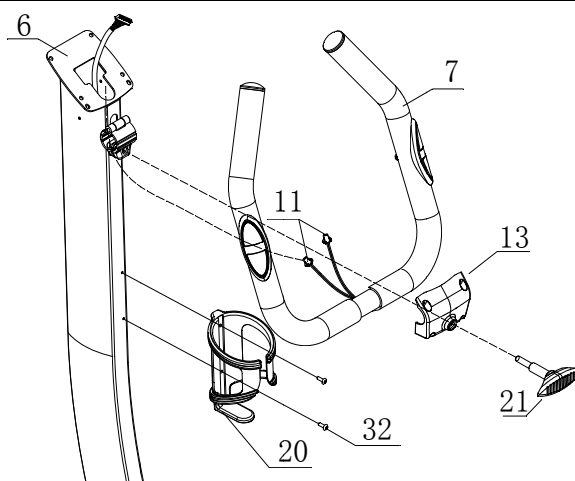

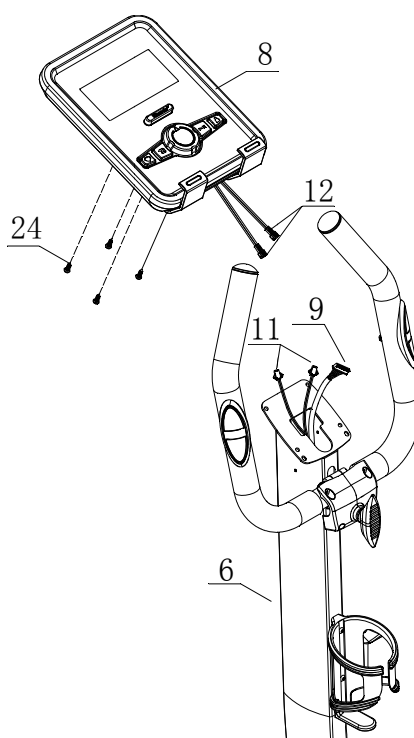

## STEP 8.

#24	<b>X4</b>
	



## STEP 9.

#32	<b>X4</b>
	

#87	<b>X4</b>
	

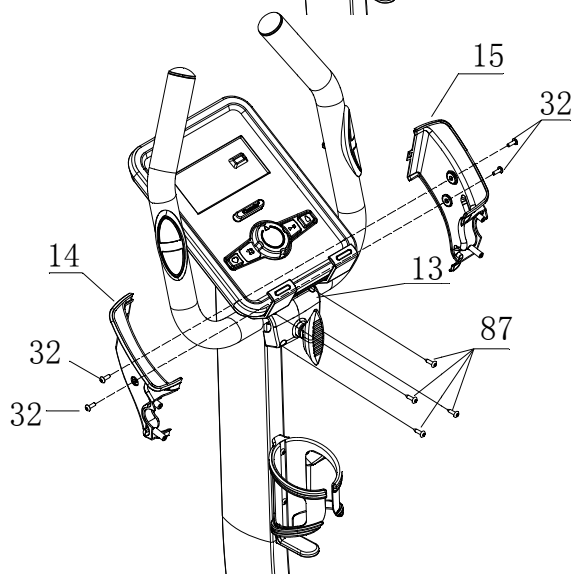



# Assembly Instruction

## STEP 10.

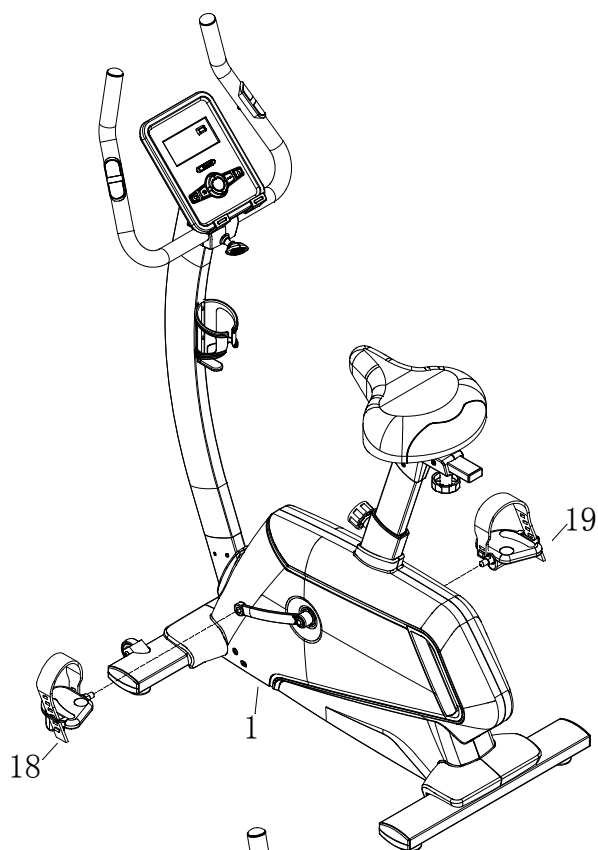

## STEP 11.

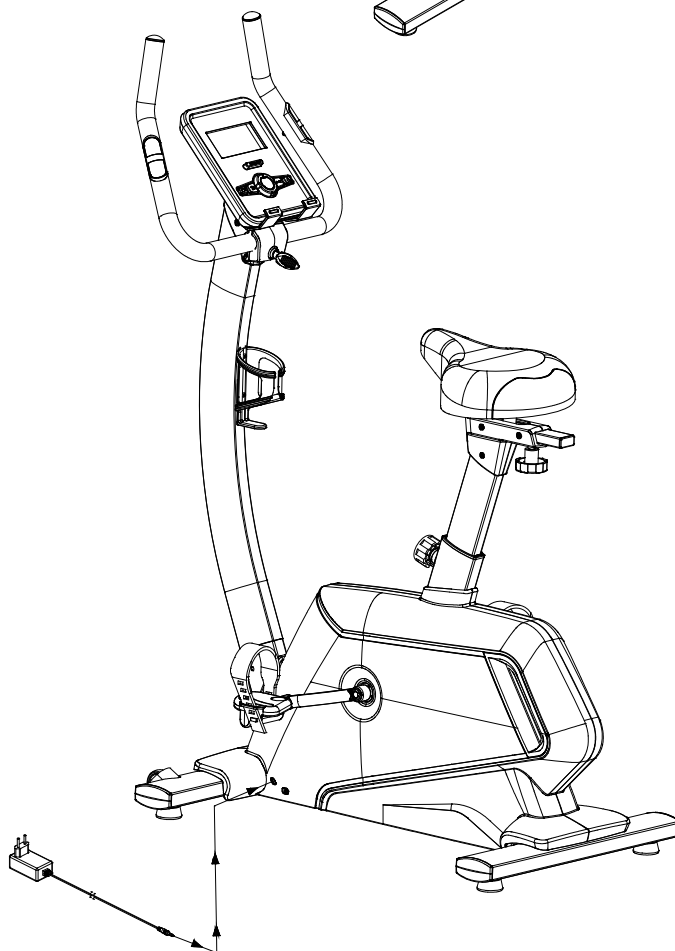

# *Console Instructions*

## **SM3760**



### **DISPLAY FUNCTIONS**

ITEM	DESCRIPTION
<b>TIME</b>	Count up - No preset target, Time will count up from 00:00 to maximum 99:59 with each increment is 1 minute. Count down - If training with preset Time, Time will count down from preset to 00:00. Each preset increment or decrement is 1 minute between 00:00 to 99:00.
<b>SPEED</b>	Displays current training speed. Maximum speed is 99.9 KM/H or ML/H.
<b>RPM</b>	Displays the Rotation Per Minute. Display range 0~15~999
<b>DISTANCE</b>	Accumulates total distance from 0.00 up to 99.99 KM or ML. The user may preset target distance data by using UP/DOWN button. Each preset increment or decrement is 0.1KM or ML between 0.00 to 99.90.
<b>CALORIES</b>	Accumulates calories consumption during training from 0 to maximum 9999 calories. (This data is a rough guide for comparison of different exercise sessions which can not be used in medical treatment.)
<b>PULSE</b>	User may set up target pulse from 0 - 30 to 230; and computer buzzer will beep when actual heart rate is over the target value during workout.
<b>WATTS</b>	Display current workout watts. Display range 0~999.
<b>MANUAL</b>	Manual mode workout.
<b>BEGINNER</b>	4 PROGRAM selection.
<b>ADVANCE</b>	4 PROGRAM selection.
<b>SPORTY</b>	4 PROGRAM selection.
<b>CARDIO</b>	Target HR training mode.
<b>WATT PROGRAM</b>	WATT constant training mode.

**KEY FUNCTION**

ITEM	DESCRIPTION
Up (Encoder)	Increase resistance level Setting selection.
Down (Encoder)	Decrease resistance level Setting selection.
Mode / Enter	Confirm setting or selection.
Reset	Press and hold for 2 seconds, computer will reboot and start from user setting. Reverse to main menu during preset workout value or stop mode.
Start/ Stop	Start or Stop workout.
Recovery	Test heart rate recovery status.
Body fat	In stop mode, press it for body fat measurement

**OPERATION:**

**POWER ON**

Plug in power supply, computer will power on and display all segments on LCD for 2 seconds (Drawing 1).

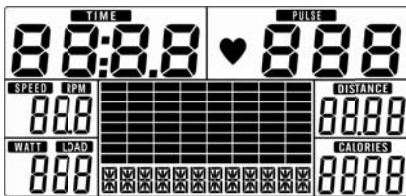

Drawing 1

**WORKOUT SELECTION**

Use UP or DOWN(Encoder) to select workout Manual (Drawing 2)→ Beginner(Drawing 3)→ Advance(Drawing 4)→ Sporty(Drawing 5)→ Cardio(Drawing 6)→ Watt(Drawing 7).



Drawing 2



Drawing 3



Drawing 4



Drawing 5



Drawing 6



Drawing 7

### Manual Mode

Press START in main menu may start workout in manual mode.

1. Use UP or DOWN(Encoder) to select workout program, choose Manual and press MODE / ENTER to get into.
2. Use UP or DOWN(Encoder) to set TIME (Drawing 8), DISTANCE (Drawing 9), CALORIES (Drawing 10), PULSE (Drawing 11) and press MODE / ENTER to confirm.
3. Press START/STOP keys to start workout. Use UP or DOWN(Encoder) to adjust load level. Load level display in WATT window, no adjusting for 3s, it will switch to display WATT (Drawing 12).
4. Press START/STOP keys to pause workout. Press RESET to reverse to main menu.



Drawing 8



Drawing 9



Drawing 10

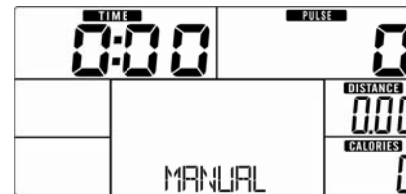

Drawing 11

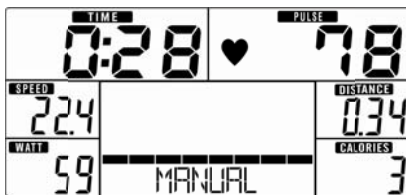

Drawing 12

### Beginner Mode

1. Use UP or DOWN(Encoder) to select workout program, choose Beginner mode and press MODE / ENTER to get into.
2. Use UP or DOWN(Encoder) to select Beginner program 1~4 (Drawing 13) and press MODE/ENTER to get into.
3. Use UP or DOWN(Encoder) to set TIME.
4. Press START/STOP key to start work. Use UP or DOWN(Encoder) to adjust load level.
5. Press START/STOP key to pause workout. Use RESET to reverse to main menu.

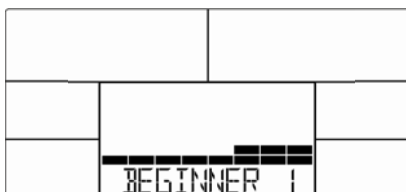

Drawing 13

### Advance Mode

1. Use UP or DOWN(Encoder) to select workout program, choose Advance mode and press MODE / ENTER to get into.
2. Use UP or DOWN(Encoder) to select Advance program 1~4 (Drawing 14) and press MODE / ENTER to get into.
3. Use UP or DOWN(Encoder) to set TIME.
4. Press START/STOP key to start workout. Use UP or DOWN(Encoder) to adjust load level.
5. Press START/STOP key to pause workout. Use RESET to reverse to main menu.

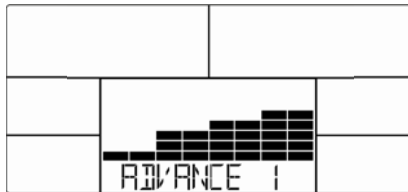

Drawing 14

**Sporty Mode**

1. Use UP or DOWN(Encoder) to select workout program, choose Sporty mode and press MODE / ENTER to get into.
2. Use UP or DOWN(Encoder) to select Sporty program 1~4 (Drawing 15)and press MODE / ENTER to get into.
3. Use UP or DOWN(Encoder) to set TIME.
4. Press START/STOP key to start workout. Use UP OR DOWN(Encoder) to adjust load level.
5. Press START/STOP key to pause workout. Use RESET to reverse to main menu.

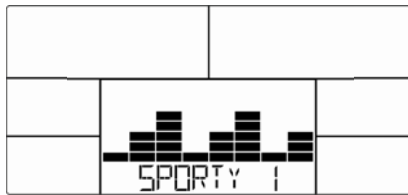

Drawing 15

**Cardio Mode**

1. Use UP or DOWN(Encoder) to select workout program, choose H.R.C. and press MODE/ENTER to get into.
2. Use UP or DOWN(Encoder) to set Age (Drawing 16).
3. Use UP or DOWN(Encoder) to select 55% (Drawing 17), 75%, 90% or TAG (TARGET H.R.) (default: 100).
4. Use UP or DOWN(Encoder) to set workout TIME.
5. Press START/STOP Key to start or stop workout. Use RESET to reverse to main menu.

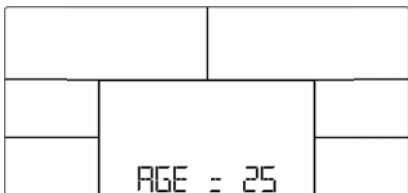

Drawing 16



Drawing 17

**Watt Mode**

1. Use UP or DOWN(Encoder) to select workout program, choose WATT and press MODE/ENTER to get into.
2. Use UP or DOWN(Encoder) to set WATT target. (default: 120, Drawing 18).
3. Use UP or DOWN(Encoder) to set TIME.
4. Press START/STOP key to start workout. Use UP or DOWN (Encoder) to adjust Watt level.
5. Press START/STOP key to pause workout. Use RESET to reverse to main menu.



Drawing 18

**RECOVERY**

After exercising for a period, keep holding on hand grips or wearing chest strap and press RECOVERY key. All function display will stop except "TIME" starts counting down from 00:60 to 00:00(Drawing 19). Screen will display your heart rate recovery status with the F1, F2... to F6. F1 is the best, F6 is the worst(Drawing 20). User may keep exercising to improve the heart rate recovery status. (Press the RECOVERY button again to return the main display.)



Drawing 19

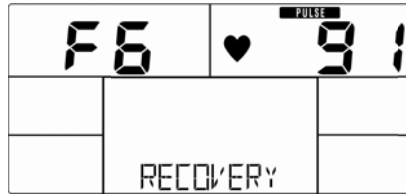

Drawing 20

**BODY FAT**

1. In STOP mode, press the BODY FAT key to start body fat measurement.
2. Console will remind to input user GENDER (Drawing 21), AGE, HEIGHT, WEIGHT, then begin to measure.
3. During measuring, users have to hold both hands on the hand grips and the LCD will display "=" "=" (Drawing 22) for 8 second until computer finishes measuring.
4. LCD will display BODY FAT advice symbol, BODY FAT percentage (Drawing 23), BMI (Drawing 24) for 30 seconds.
5. Error message:

\*The LCD displays "=" "=" (Drawing 25) - means the hands are not on the pulse sensors correctly or the chest strap is not on correctly.

\*E-1 - There is no heart rate signal input detected.

\*E-4 - Occurs when FAT% is below 5 or exceeds 50 and BMI result is below 5 or exceeds 50 (Drawing 26).

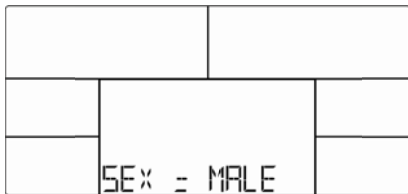

Drawing 21

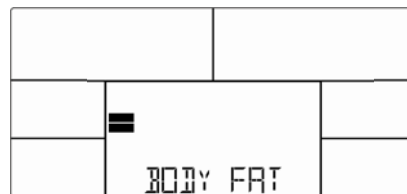

Drawing 22

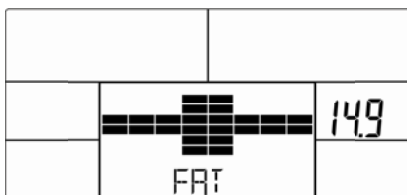

Drawing 23

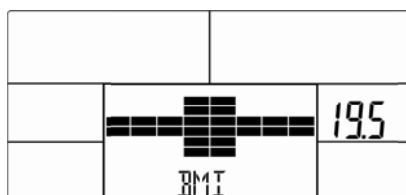

Drawing 24

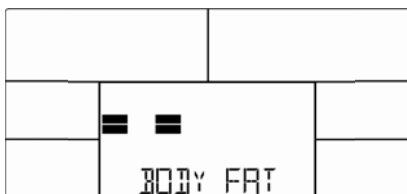

Drawing 25



Drawing 26

**Noted:**

1. After 4 minutes without pedaling or pulse input, console will enter into power saving mode. Press any key may wake the console up.
2. When computer acts abnormally, please unplug the adaptor and plug in again.

**APP**



- 1.This console can connect APP on the smart device by Bluetooth or Tune linc.
2. Once console is connected to smart device via Bluetooth or Tune linc, the console will power off.

**General fitness tips**

Start your exercise program slowly, i.e. one exercise unit every 2 days. Increase your exercise session week by week. Begin with short periods per exercise and then increase these continually. Start slowly with the exercise sessions and don't set yourself impossible targets. In addition to these exercises, do other forms of exercises such as jogging, swimming, dancing and/or cycling.

Always warm up thoroughly before exercising. To do so, carry out at least five minutes of stretching or gymnastic exercises to avoid muscle strains and injuries.

Check your pulse regularly. If you do not have pulse measuring instrument, ask your GP how you can measure your heart rate effectively. Determine your personal exercise frequency range to achieve optimal training success. Take into account both your age and your level of fitness. The table on page 16 will give you a reference point for determining the optimal exercise pulse.

Make sure you breathe regularly and calmly when exercising.

Take care to drink enough while exercising. This ensures that the liquid requirement of your body is satisfied. Consider that the recommended drinking amount of 2-3 liters per day is strongly increased through physical strain. The fluid you drink should be at room temperature.

When exercising on the device always wear light and comfortable clothing as well as sports shoes. Do not wear any loose clothing that could tear or become caught in the device whilst exercising.

# Exploded drawing

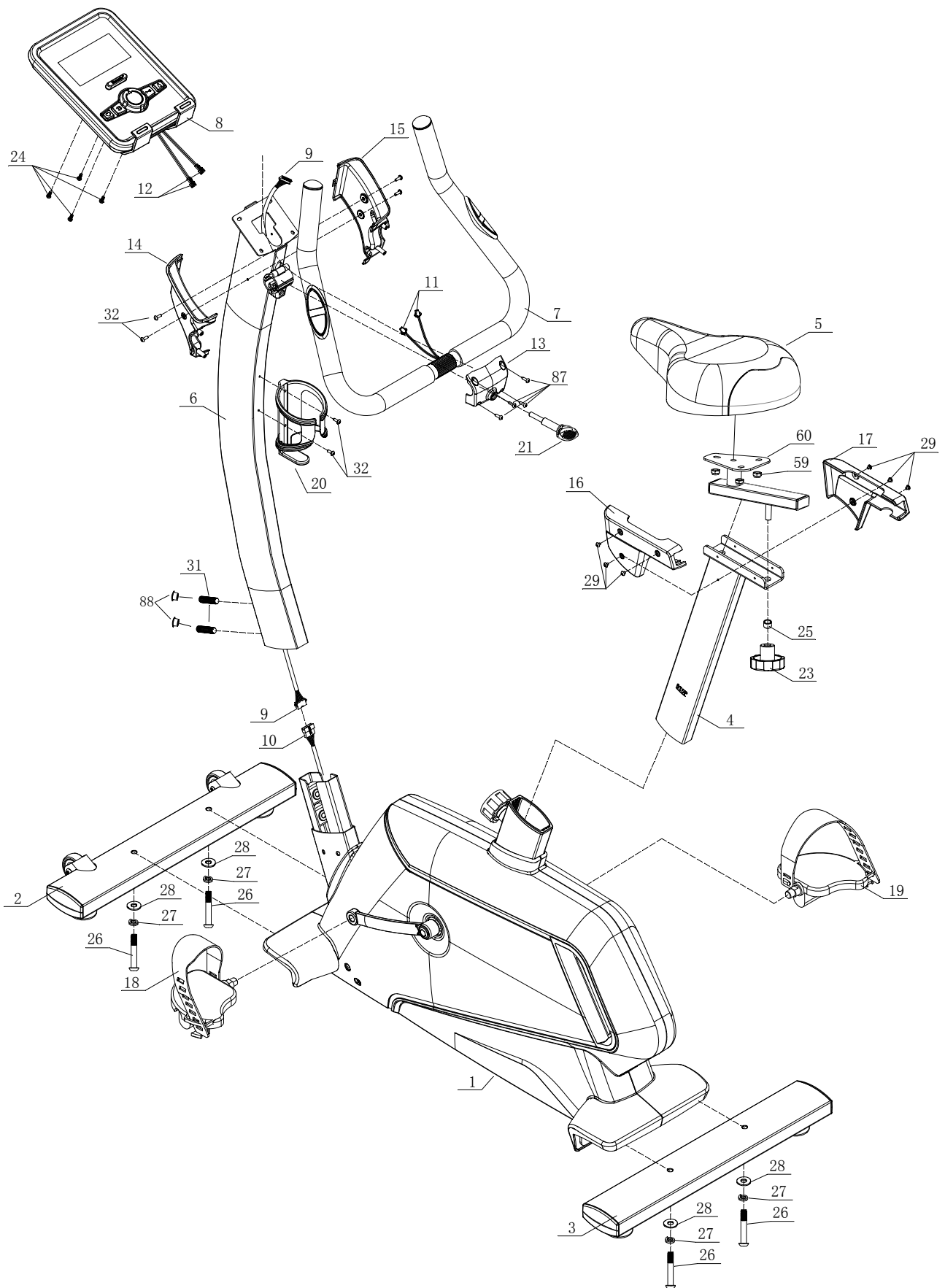



# ***MAINTENANCE***

## **Cleaning**

The upright bike can be cleaned with a soft cloth and mild detergent. Do not use abrasives or solvents on plastic parts. Please wipe your perspiration off the upright bike after each use. Be careful not get excessive moisture on the computer display panel as this might cause an electrical hazard or electronics to fail.

Please keep the upright bike, specially, the computer console, out of direct sunlight to prevent screen damage.

Please inspect all assembly bolts and pedals on the machine for proper tightness every week.

## **Storage**

Store the upright bike in a clean and dry environment away from children.

# Exploded drawing

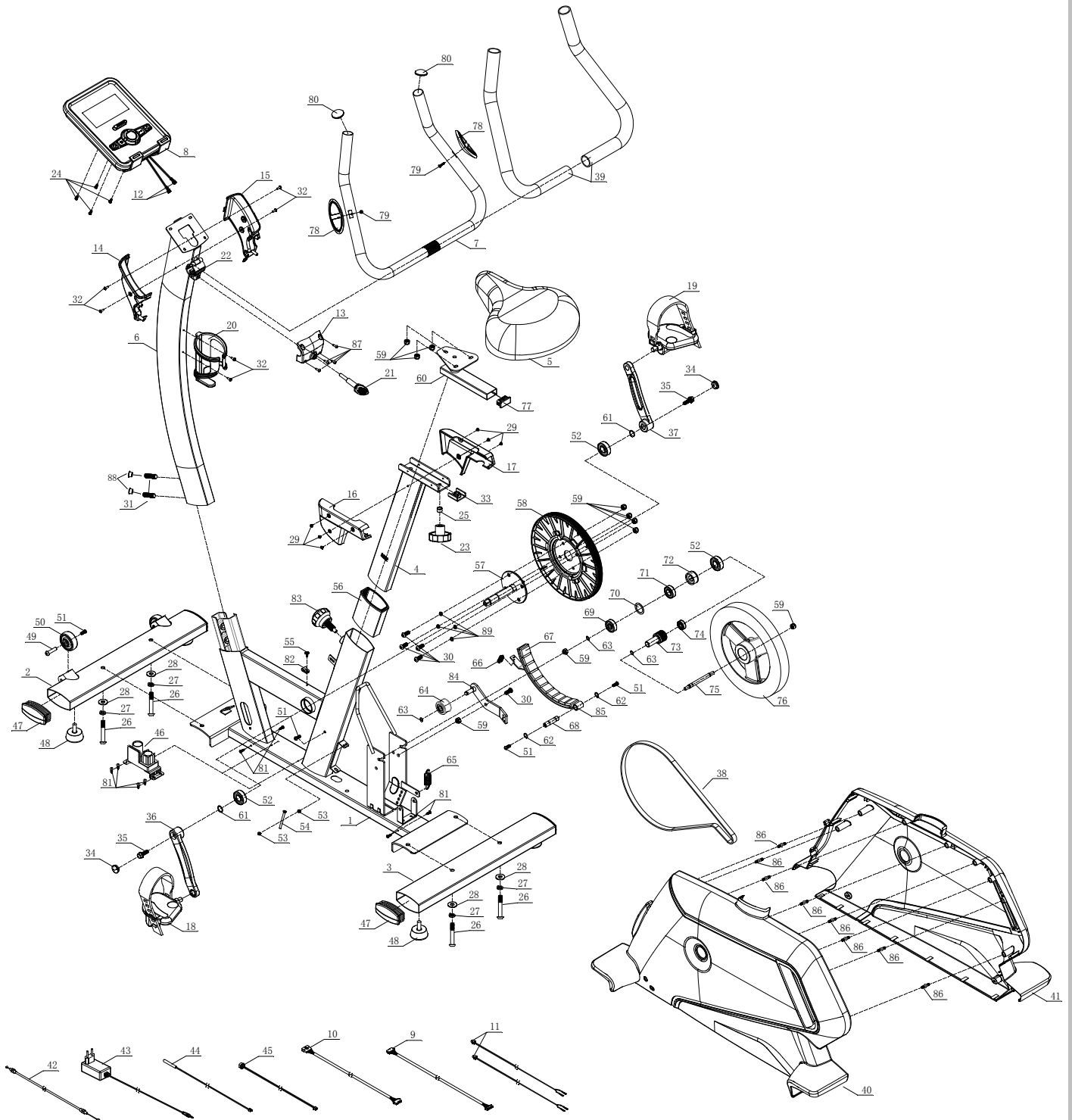

## *Part List*

NO.	NAME	DESCRIPTION	QTY
1	Main frame		1
2	Front stabilizer		1
3	Rear stabilizer		1
4	Saddle post		1
5	Saddle		1
6	Upper Upright post		1
7	Handlebars		1
8	Console		1
9	Console communication wire		1
10	Motor communication wire		1
11	Handle pulse connection wire		2
12	Console outset		1
13	Handlebar front	89×73.5×35	1
14	Handlebar cover-Left	176.5×53.2×117.5	1
15	Handlebar cover-Right	176.5×53.2×117.5	1
16	Saddle cover(L)	195×28.5×111.8	1
17	Saddle cover(R)	195×31.5×111.8	1
18	Pedal(L)		1
19	Pedal(R)		1
20	Bottle holder	Φ93×150	1
21	T-shaped rotary knob	M8×30	1
22	Handlebar clamp ring		1
23	Seat post rotary knob		1
24	Philips C.K.S. self-tapping screw	M5×10	4
25	Bushing tube	Φ25×Φ19×60	1
26	Allen C.K.S. half thread screw	M10×70×20	4
27	Spring washer	Φ10	4
28	Curved washer	Φ10.5×R128×t1.5	4
29	Philips pan head full thread screw	M4×6	6
30	Allen C.K.S. full thread screw	M8×20	5
31	Allen flat end set bolt	M12×60	2
32	Phillips pan head full thread screw	M4×16	6
33	Saddle locking piece		1
34	Crank cover	Φ23×6×M22×P1.0	2
35	Hex flange full thread screw	5/16-18UNC-1"	2
36	Crank(L)		1
37	Crank(R)		1

## *Part List*

NO.	NAME	DESCRIPTION	QTY
38	Motor belt	440PJ6	1
39	Foam grip	Φ 32×t3.0×600	2
40	Motor cover - left	974.8×78.7×575.3	1
41	Motor cover - right	974.8×83.2×575.3	1
42	Brake line	L-450×Φ5×Φ1.5×M6×15	1
43	Power adapter	240V	1
44	Magnetic sensor		1
45	Power communication wire		1
46	Magnet motor		1
47	End cap	45×90×t1.5	4
48	Feet pad	Φ49×22×M10×26	4
49	Allen C.K.S. hollow screw	Φ8×33×M6×15	2
50	Wheels	Φ54.5×23.5	2
51	Allen C.K.S. full thread screw	M6×15	5
52	Deep groove ball bearing	6203-2RS	3
53	Hex nut	M5	2
54	Hex full head screw	M5×60	1
55	Philips washer head end-cutting and self-tapping bolt	ST4×12	1
56	Saddle post bushing	115×90×45	1
57	Crank axis	Φ17×150	1
58	Belt pulley	Φ263×22	1
59	Hex locking nut	M8	10
60	Saddle adjustment		1
61	Circlip for shaft	Φ17	2
62	Circlip for shaft	Φ12	2
63	Circlip for shaft	Φ10	3
64	Tension wheel	Φ38×22	1
65	Tension spring	Φ18×Φ2.0×16	1
66	Brake tension spring	Φ11.5×Φ1.2×13	1
67	Square magnet	30×25×t12	10
68	Magnetic control axis	Φ12×50	1
69	Deep groove ball bearing	6300-2RS	1
70	Flat washer	Φ34×Φ25×t1.0	1
71	Deep groove ball bearing	6003-2RS	1
72	One-way kingpin ball bearing	Φ35×Φ17×16	1
73	Small belt pulley	Φ30×64	1
74	Deep groove ball bearing	6000-2RS	1

## *Part List*

NO.	NAME	DESCRIPTION	QTY
75	Flywheel axis	Φ10×114.5	1
76	Flywheel	Φ280	1
77	Square pipe plug	20×40×t1.5	1
78	Handle pulse		2
79	Philips C.K.S. self-tapping screw	ST4×20	2
80	Round pipe plug	Φ 28×t1.5	2
81	Philips C.K.S. self-tapping screw	ST4×16	8
82	Fixed magnet		1
83	Rotary hand bolt	Φ 9×M16×P1.5×83	1
84	Fixed tension wheel		1
85	Magnet		1
86	Plastic bolt	Φ 9×Φ 6.1×27	8
87	Philips C.K.S. self-tapping screw	ST4×12	4
88	Hole plug	Φ 15	2
89	Spring washer	Φ 8	4
90	Allen pan head full thread screw	M8×38	1



## **UPRIGHT BIKE**

**Model No: ABX600**

To register your warranty, please go to  
[www.gpisports.com.au](http://www.gpisports.com.au)

Distributed Exclusively by :  
**GPI Sports & Fitness**  
**275 Wellington Road**  
**Mulgrave, VIC, 3170**  
**Australia.**