

# OXFORD II

## Owner's Guide

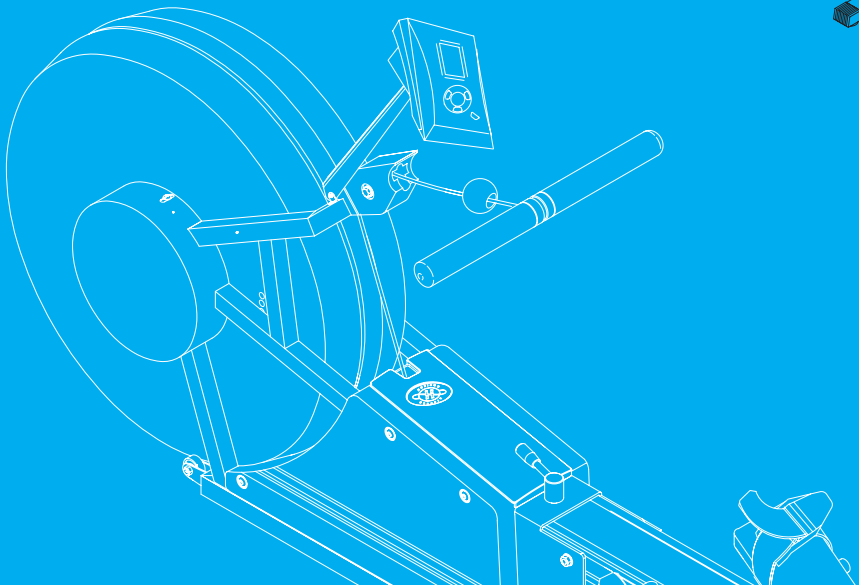



# TABLE OF CONTENTS

Safety Instructions .....	3
Parts & Hardware .....	6
Assembly Instructions .....	7
Know Your Air Rower.....	10
Exercise Guidelines .....	12
Routine Maintenance.....	13
Developing a Fitness Program & Warm up a Cool Down .....	14
Fitness Goals .....	15
Weekly Log Sheets .....	16
Monthly Log Sheets .....	17
Home Warranty .....	18



## CAUTION

Read all precautions and instructions in this manual before using this equipment.  
Save this manual for future reference.

# KNOW YOUR AIR ROWER

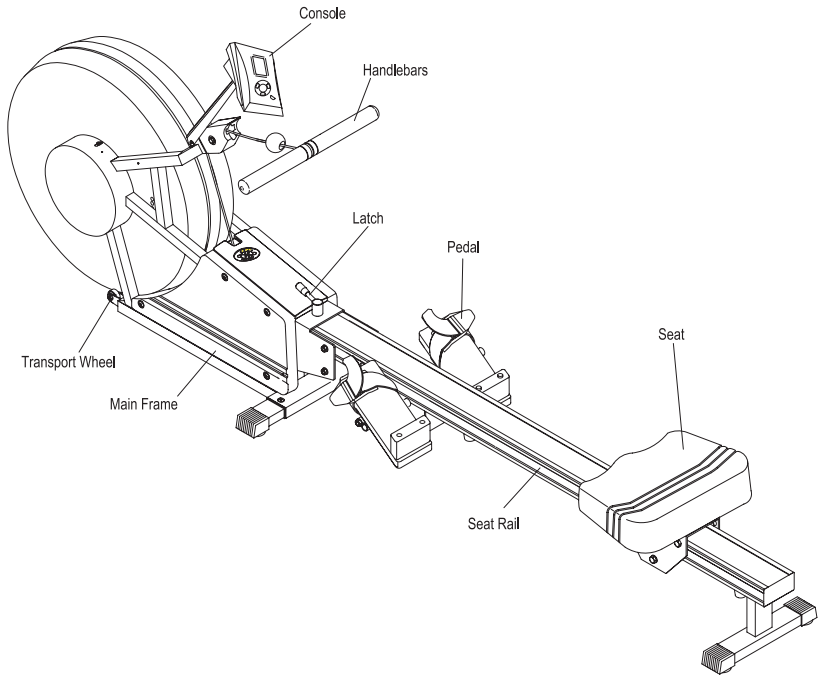

Congratulations on choosing an Horizon Fitness Air Rower. You've taken an important step in developing and sustaining an exercise program! Your Horizon Fitness Air Rower is a tremendously effective tool for achieving your personal fitness goals. Regular use of your Horizon Fitness Rower can improve the quality of your life in so many ways.

Here are a few of the health benefits of aerobic exercise:

- Weight Loss
- A Healthier Heart
- Improved Muscle Tone
- Increased Daily Energy Levels
- Reduced Stress
- Help in Countering Anxiety and Depression
- An Improved Self Image

## IMPORTANT SAFETY INSTRUCTIONS

### WARNING!

To reduce the risk of serious injury, read the important safety precautions before using this equipment.

1. Read all instructions in this manual before using this equipment.
2. Use this equipment only as described in this Owner's Manual.
3. Never allow children to use this unit.
4. Inspect and tighten all parts before using this equipment. Replace any worn parts immediately.
5. Observers should be warned to stay away from unit while in use. Failure to do so may cause injury to observer and/or exerciser.
6. Never stick fingers or foreign objects through fan cover. Keep small children away from the air rower while in use. Failure to do so could cause injury to child or unit.
7. Never remove any of the safety guards that are attached to your air rower. If removal is required for any service or maintenance, this should be done only by your authorized dealer and must be replaced before use.
8. Wear appropriate workout attire, including running or aerobic shoes, when using the rower.

**Warning:** Before beginning any exercise program, always consult your physician. If you experience chest pains, nausea, dizziness or shortness of breath, stop exercising and consult your physician before continuing.

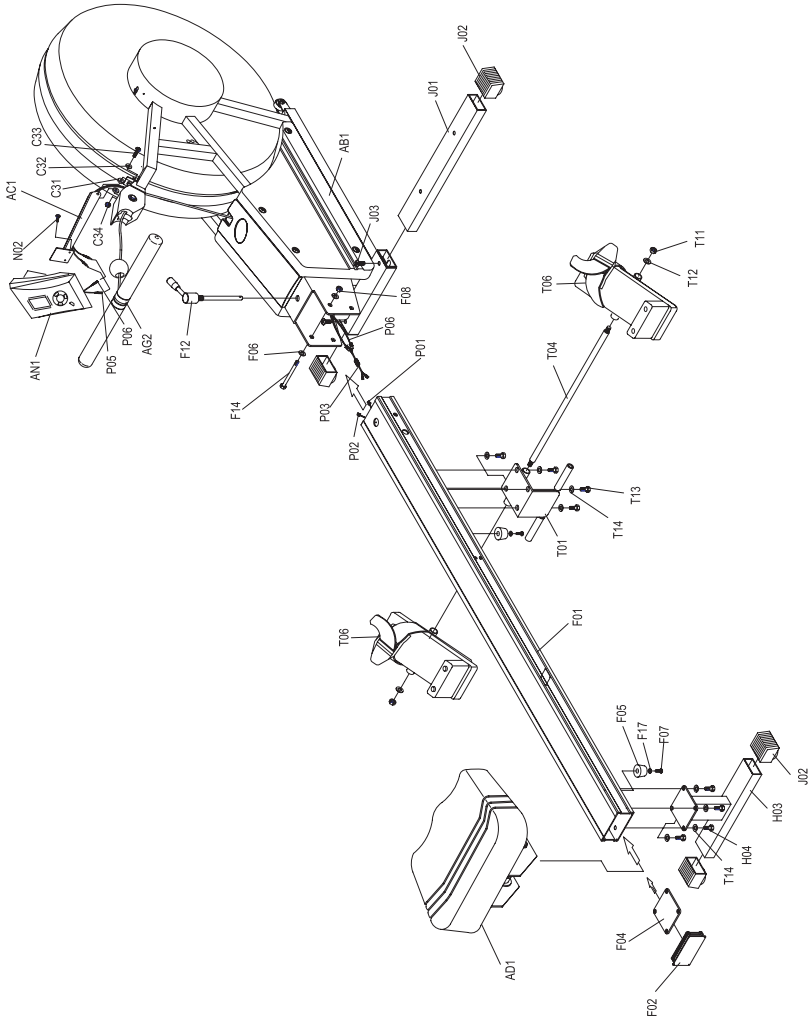

# UNPACKING

Unpack your air rower on a level flat surface where you will be using it. Verify that the following parts are included:

## Parts

- 1 Main Frame (AB1)
- 1 Front Foot (J01)
- 1 Rear Foot (H03)
- 1 Rail (F01)
- 1 Seat Assembly (AD1)
- 2 Pedal Set (T06)
- 1 Pedal Rod (T04)
- 1 Pedal Bracket (T01)
- 1 Rail Latch (F12)
- 1 Rail End Cap (F02)
- 4 Foot End Cap (J02)
- 1 Rail Rod (F14)
- 2 Seat Stop Bumper (F05)
- 1 Rear Foot Position Plate (F04)
- 1 Console (ANL)
- 1 Console Mast (ACL)

## Hardware



10mm x 23mm Washer (F06)  
Quantity: 2  
Pedal



8mm x 20mm Washer (T12)  
Quantity: 2  
Seat Rail



5mm x 12mm Washer (F17)  
Quantity: 2  
Seat Stop Bumper



8mm x 25mm Washer (C31)  
Quantity: 2  
Console Mast



8mm x 20mm Washer (C32)  
Quantity: 1  
Console Mast



10mm x 20mm Spring Washer (T14/H05)  
Quantity: 2  
Seat Rail



M8 x 19mm L Bolt (T13)  
Quantity: 4  
Pedal Bracket



M8 x 65mm L Bolt (C33)  
Quantity: 1  
Console Mast



Nylon Nut (C34) M8  
Quantity: 1  
Console Mast



W3/8" Nylon Nut (T11/F08)  
Quantity: 3  
Pedal & Seat Rail



W5/16" x 13mm L Bolt (J03)  
Quantity: 2  
Front Foot



M8 x 19mm L Bolt (H04)  
Quantity: 4  
Rear Foot



M5 x 15mm L Bolt (F07)  
Quantity: 2  
Seat Stop Bumper



Wrench  
Quantity: 2



Allen  
Quantity: 1

# ASSEMBLY INSTRUCTIONS

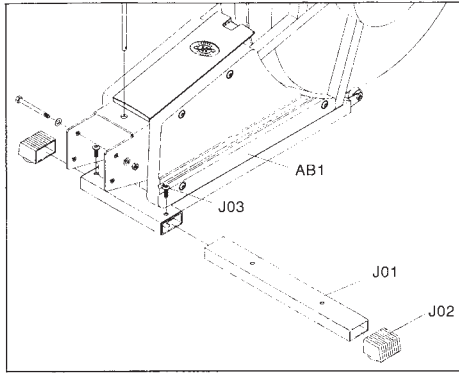

## FRONT FOOT ASSEMBLY

- STEP 1 Gently push the Front Foot (J01) through the Foot Bracket and align the holes on Foot Bracket with the holes in the Foot.
- STEP 2 Tighten the Front Foot (J01) using two Bolts (J03).
- STEP 3 Press Foot End Cap (J02) to both ends of the Front Foot (J01).

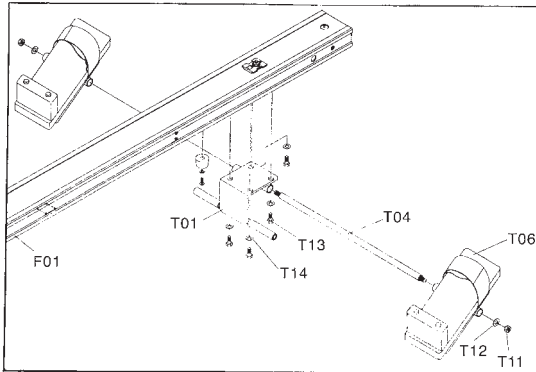

## PEDAL ASSEMBLY

- STEP 1 Attach the Pedal Bracket (T01) to the Seat Rail (F01) using four Bolts (T13) and Washers (T14).
- STEP 2 Slide the Pedal Rod (T04) through the Pedal Bracket (T01).
- STEP 3 Slide the Left and Right Pedal (T06) onto the Pedal Rod (T04) and fix them using two Washers (T12) and Nylon Nuts (T11).

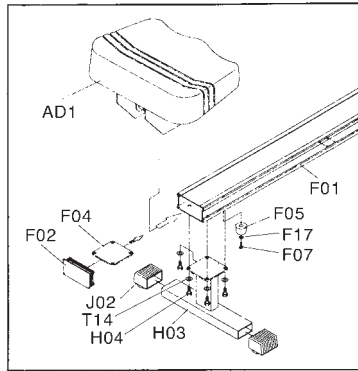

### REAR FOOT AND SEAT ASSEMBLY

- STEP 1 Slide the Seat Assembly (AD1) onto the Seat Rail (F01).
- STEP 2 Attach the Seat Stop Bumper (F05) to the Seat Rail (F01) using two Bolts (F07) and Washers (F17).
- STEP 3 Place the Rear Foot Position Plate (F04) in the Seat Rail (F01) close to the edge. Attach the Rear Foot (H03) to the Seat Rail (F01) and align the four holes in the Seat Rail (F01) with the four holes in the frame lip. Thread four Bolts (H04) with Spring Washers (T14) through the frame lip into the Rear Foot Position Plate (F04) and tighten them.
- STEP 4 Press the Rail End Cap (F02) to the Seat Rail (F01).

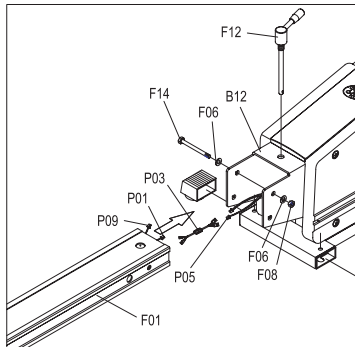

### RAIL AND WIRES ASSEMBLY

- STEP 1 Connect Sensor (P01) and Heart rate Sensor wire with the connection Cable (P03) . Be careful with safety instructions.
- STEP 2 Place the Seat Rail (F01) into the Rail Bracket (B12). Slide the Seat Rail Rod (F14) with the Washer (F06) through the holes in the Rail Bracket (B12) and tighten them using Nylon Nut (F08) and Washer (F06).

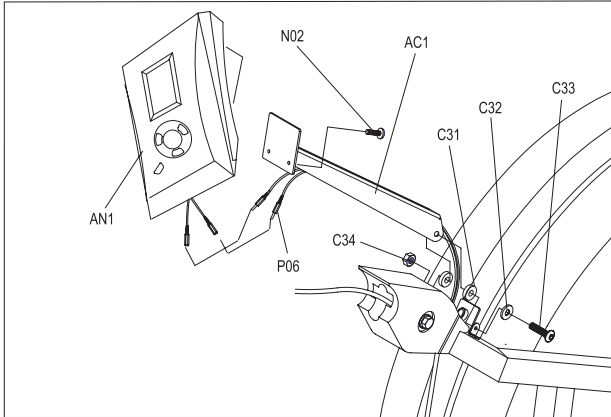

## CONSOLE AND MAST ASSEMBLY

- STEP 1 Place Console Mast (AC1) onto the mounting bracket on the frame with Bolts (C33) and Washers (C32). In the meantime put thick Washers (C31) on both console masts, then use nylon nut to tighten the console mast.
- STEP 2 Get the Console (AN1), connect 2 Sensor Wires (P06) with the port on Console (AN1), put the console on the console mast mounting bracket and use the screws (attached on console) to tighten it.

# USING YOUR AIR ROWER

## GETTING STARTED

Your air rower is powered by you. There is no motor or brake in this unit. The console is powered by 2 AA batteries, which are replaceable through the back side of the console. Removing the batteries will erase all functional values (including TOTAL function)

## AUTO POWER ON/OFF

The Power will be automatically turned on when you Push the Mode button on the computer. After you have completed your workout the console will retain the data from your workout until you press the reset button to begin your next workout. To conserve batteries, the console will automatically shut off after a short period of time.

## USING THE CONSOLE :

### MODE

Press to select each function for presetting.

### RESET

Press to reset each function, or hold down for 4 seconds to have all function value totally reset.

### SET

Press to preset count, time, pulse, distance, and calorie values.

### ST / STOP

Press to start or stop the computer function working.

## FUNCTIONS

### COUNT

Accumulates counts up to 9999 or from the preset value count down to zero.

### TIME

Accumulates total working time up to 99:59, or from preset time count down to zero.

### PULSE

Shows the heart rate during exercise. Note: The chest strap is required to display your heart rate.

### DISTANCE

Accumulates total distance from zero up to 99.90 km, or from the preset values count down to zero.

### CALORIES

Accumulates calorie consumption during exercise from zero to MAX. value 999 cal, or from preset value count down to zero. (This data is a rough guide for comparison of different exercise sessions which can not be used in medical treatment).

### STROKES / MIN

Displays the counts per minutes.

\*\*The functions of pulse, distance, calories and strokes / MIN are in one display, The computer will be auto scan between each function when you start exercising.

### NOTE!

- Without any signal for 5 minutes, the LCD display will shut off automatically, all values are saved, and if any key is pressed or exercise resumed the values shall re-appear.
- Press mode to select between the functions should be under stop working condition.
- If there is an improper display on the monitor, please re-install the batteries.

## EXERCISE GUIDELINES

Always consult your physician before beginning an exercise program.

### HOW OFTEN?

The American Heart Association recommends that you exercise at least 3 to 4 days per week to maintain cardiovascular fitness. If you have other goals such as weight or fat loss, you will achieve your goal faster with more frequent exercise. Whether it's 3 days or 6 days, remember that your ultimate goal should be to make exercise a lifetime habit. Many people are successful staying with a fitness program if they set aside a specific time of day to exercise. It doesn't matter whether it's in the morning before your shower, during your lunch hour or while watching the evening news. What's more important is that it's a time that allows you to keep a schedule, and a time when you won't be interrupted. If you are to be successful with your fitness program, you have to make it a priority in your life. So decide on a time, pull out your day planner and pencil in your exercise times for the next month!

### HOW LONG?

For aerobic exercise benefits, it's recommended that you exercise from between 24 and 32 minutes per session. But start slowly and gradually increase your exercise times. If you've been sedentary during the past year, it may be a good idea to keep your exercise times to as little as five minutes initially. Your body will need time to adjust to the new activity. If your goal is weight loss, a longer exercise session at lower intensities has been found to be most effective. A workout time of 48 minutes or more is recommended for best weight loss results.

### PERCEIVED EXERTION LEVEL

The second and simpler way to gauge your exercise intensity is to evaluate your perceived exertion level. While exercising if you are too winded to maintain a conversation without gasping, you are working out too hard. A good rule of thumb is to work to the point of exhilaration, not exhaustion. If you cannot catch your breath, it's time to slow down. Always be aware of other warning signs of overexertion.

## ROUTINE MAINTENANCE

### WHAT KIND OF ROUTINE MAINTENANCE IS REQUIRED?

We use sealed bearings throughout our air rowers so lubrication is not needed. The most important maintenance step is to simply wipe your perspiration off the air rowers after each use.

### HOW DO I CLEAN MY HORIZON AIR ROWER?

Clean with soap and water cleaners only. Never use solvents on plastic parts. Cleanliness of your Horizon Fitness air rower and its operating environment will keep maintenance problems and service calls to a minimum. For this reason, Horizon preventative recommends that the following preventative maintenance schedule be followed.

#### AFTER EACH USE (DAILY)

Wipe off any perspiration with a damp cloth.

#### WARNING!

- Wipe down the air rower with a damp cloth. Never use solvents, as they can cause damage to the air rower.

#### EVERY WEEK

Clean underneath the air rower, following these steps:

- Move the air rower to a remote location.
- Wipe or vacuum any dust particles or other objects that may have accumulated underneath the air rower.
- Return the air rower to its previous position.

#### EVERY MONTH

- Inspect all assembly bolts and pedals on the machine for proper tightness.

## DEVELOPING A FITNESS PROGRAM

### STRETCH FIRST

Before using your Horizon Fitness product, it is best to take a few minutes doing a few gentle stretching exercises. Stretching prior to exercise will improve flexibility and reduce chances of exercise related injury. Ease into each of these stretches with a slow gentle motion. Do not stretch to the point of pain. Make sure not to bounce while doing these stretches.

### WALL PUSH

Stand near a wall with the toes of one foot about 18" from the wall, and the other foot about 12" behind the other foot. Lean forward, pushing against the wall with your palms. Keep your heels flat and hold this position for a count of 15 seconds. Make sure that you do not bounce while stretching. Alternate positions of your feet and repeat for a total of 8 repetitions.

### STANDING QUADRICEPS STRETCH

Using a wall to provide balance, grasp your left ankle with your left hand and hold your foot against the back of your thigh for a count of 15 seconds. Repeat with your right ankle and hand, and continue alternating for a total of 8 repetitions.

### SEATED TOE TOUCH

Sit on the floor with your legs together and straight out in front of you. Do not lock your knees. Extend your fingers towards your toes and hold for a count of 15 seconds. Make sure that you do not bounce while stretching. Sit upright again. Repeat for a total of 8 repetitions.

## THE IMPORTANCE OF WARM UP AND COOL DOWN

### WARM UP

The first 2 to 5 minutes of a workout should be devoted to warming up. The warm-up will limber your muscles and prepare them for more strenuous exercise. Make sure that you warm-up on your Horizon Fitness product at a slow pace.

### COOL DOWN

Never stop exercising suddenly! A cool-down period allows your heart to readjust to the decreased demand. Make sure that your cool down period consists of a very slow pace to allow your heart rate to lower. After the cool-down, repeat the stretching exercises listed above to loosen and relax your muscles.

## ACHIEVING YOUR FITNESS GOALS

An important step in developing a long term fitness program is to determine your goals. Is your primary goal for exercising on your Horizon Fitness Air Rower to lose weight? Improve muscle? Burn Stress? Prepare for the spring racing schedule? Knowing what your goals are will help you develop a more successful exercise program. Below are some common exercise goals:

- Weight Loss
- Improve Body Shape and Tone
- Increased Energy Level
- Improved Sports Performance
- Improved Cardiovascular Endurance
- Weight Maintenance
- Strengthen Leg Muscles
- Improved Sleep Patterns
- Stress Reduction

If possible try to define your personal goals in precise, measurable terms, and then put your goals in writing. The more specific you can be, the easier it will be to track your progress. If your goals are long term, divide them up into monthly and weekly segments. Longer term goals can lose some of the immediate motivation benefits. Short term goals are easier to achieve. Your Horizon Fitness Air Rower console provides you with several readouts that can be used to record your progress. You can track Distance, Calories or Time. Time is the most important and useful of test functions.

### KEEPING AN EXERCISE DIARY

Photocopy the weekly and monthly log sheets on the following pages to make your personal exercise log book. As time goes by you'll be able to look back with pride at the work you've done. As your fitness improves, you can look back and see how far you've come.

# WEEKLY LOG SHEET

WEEK # _____		WEEKLY GOAL: _____			
DAY	DATE	DISTANCE	CALORIES	TIME	COMMENTS
SUN					
MON					
TUES					
WED					
THUR					
FRI					
SAT					
WEEKLY TOTALS					

WEEK # _____		WEEKLY GOAL: _____			
DAY	DATE	DISTANCE	CALORIES	TIME	COMMENTS
SUN					
MON					
TUES					
WED					
THUR					
FRI					
SAT					
WEEKLY TOTALS					

# MONTHLY LOG SHEET

MONTH _____		MONTHLY GOAL: _____	
WEEK #	DISTANCE	CALORIES	TIME
MONTHLY TOTALS			

MONTH _____		MONTHLY GOAL: _____	
WEEK #	DISTANCE	CALORIES	TIME
MONTHLY TOTALS			

## LIMITED HOME USE WARRANTY

### FRAME-LIFETIME

Horizon Fitness warrants the frame against defects in workmanship and materials for the lifetime of the original owner.

### ELECTRONICS & PARTS

Horizon Fitness warrants the electronic components and all original parts for a period from the date of original purchase, so long as the device remains in the possession of the original owner.

### LABOUR

Horizon Fitness shall cover the labor cost for the repair of the device for a period from the date of the original purchase, so long as the device remains in the possession of the original owner.

### EXCLUSIONS AND LIMITATIONS

This warranty applies only to the original owner and is not transferable. This warranty is expressly limited to the repair or replacement of a defective frame, electronic component, or defective part and is the sole remedy of the warranty. The warranty does not cover normal wear and tear, improper assembly or maintenance, or installation of parts or accessories not originally intended or compatible with the rowing machine as sold. The warranty does not apply to damage or failure due to accident, abuse, corrosion, discoloration of paint or plastic, or neglect. Horizon Fitness shall not be responsible for incidental or consequential damages. All returns must be pre-authorized by Horizon Fitness. Horizon Fitness' obligation under this warranty is limited to replacing or repairing, at Horizon Fitness' option, the product at one of its authorized service centers. An Horizon Fitness authorized service center must receive all products for which a warranty claim is made. These products must be received with all freight and other transportation charges prepaid, accompanied by sufficient proof of purchase. Parts and electronic components reconditioned to As New Condition by Horizon Fitness or its vendors may sometimes be supplied as warranty replacement parts and constitute fulfillment of warranty terms.

Please consult your local dealer for more warranty details.



Horizon Fitness  
800 Burton Blvd DeForest, Wisconsin 53532